

**DRIESCHER -
Outdoor Switch-Disconnecter
Type FLa 15/97**

- Rated voltage
12 kV, 24 kV, 36 kV and 37.5 kV
- Rated current
400 A and 630 A
- 1-pole and 3-pole design



15/97

**ELEKTROTECHNISCHE WERKE
FRITZ DRIESCHER & SÖHNE GMBH**

D-85366 MOOSBURG • TEL. +49 87 61 6 81-0 • FAX +49 87 61 68 11 37
<http://www.driescher.com> infoservice@driescher.de



DRIESCHER - Outdoor Switch-Disconnecter FLa 15/97

according to EN 60265-1

content

- 3 General, designs
- 4 Switching in a vacuum
- 5 Operation mode, technical data

Horizontal arrangement of the switch-disconnectors

- 6 **FLa 15/97** mounted on wooden or concrete pole
- 7 Mounting supports, cu-tension straps
- 8 **FLa 15/97 wide span system**, coupling shafts for wide span system
- 9 Arrangement according to system "Tonnenbild", arrangement for wide span system
- 10 Underframe, support bearing
- 11 Permissible tension angle, Tension units, Concrete cross-arm
- 12 **FLa 15/97 - 64W**
- 13 Accessories for tension units

Vertical arrangement of the switch-disconnectors

- 14 **FLa 15/97 - 6400**
- 15 **FLa 15/97 - 6400 1-pole design**
- 16 **FLa 15/97 - 6410 - with fuse holders**
- 17 **FLa 15/97 - 6410 SA - with fuse holders and operating fuse**
- 18 Arrangements of operators for Type **FLa 15/97 - 6400, FLa 15/97 - 6410**
- 19 Operation examples
- 20 Examples to use the switch-disconnectors

DRIESCHER - Outdoor Switch-Disconnecter FLa 15/97

General

Contrary to former outdoor load-break switches in which it was common practice for the arc to be extinguished in oil, with the new developed outdoor switch-disconnector FLa 15/97 arc extinction takes place in a vacuum interrupter.

Based on a patented insulating system there is also no liquid or gaseous medium required for the external insulation strength of the vacuum interrupters.

The vacuum quenching device is embedded in a weather-proof insulating housing.

This switchgear is therefore also recommended for special applications (e.g. in water protection areas).

The outdoor switch-disconnector is capable of switching on its rated current as well as its rated short-circuit making current via the main contact system.

The disconnecting process is implemented via the shunt-connected vacuum interrupters, resulting in no external arcing phenomena.

A fully developed eccentric make-and-break mechanism operates the vacuum interrupters and ensures Class M2 with regard to the mechanical strength (corresponds to 5000 mechanical operating cycles).

The designs FLa 15/97 correspond in their main dimensions to the switches FLa 15/60, FLa 6400 and FLa 6410 (refer to brochure 762, 763), i.e. the fixing dimensions have remained unchanged.

Also the operating linkage (brochure 775) can be used in the common design.

The switch frames and the operating shafts mounted in bronze bearings are hot-galvanized.

All insulators used in the design (brochure 712) are of cycloaliphatic cast resin.

The contacts with flanged ends in compliance with DIN 46206 as well as all other live components of the contact system are of electrolytic copper and are silver-plated in compliance with QTL 200.

Amply dimensioned cross-sections as well as the external spring mechanism at the contact jaw which provides constant contact pressure guarantee an easy and satisfactory switching, even after many years of operation.

Connecting screws with nuts, washers and lock washers are made of rustproof steel.

The outdoor switch-disconnector FLa 15/97 are available for rated voltages of 12 kV to 38.5 kV and rated currents of 400 A and 630 A, and have been tested in compliance with the valid regulations.

By using adapters it is possible to retrofit already installed equipment from the FLa 15/60 family (of the more recent design) with vacuum interrupters.

The attached earthing switches are, however, always without rapid breaking.

The external metal parts of the rapid make-and-break mechanism (actuating fork) are made of rustproof steel.

Designs

Vertical arrangement (switching angle 90°)

- FLa 15/97 - 6400
- FLa 15/97 - 6410; with fuses
- FLa 15/97 - 6410; with skew mounted fuses
- FLa 15/97 - 6410 SA; with fuse operates
- FLa 15/97 1-pole design

Horizontal arrangement

- FLa 15/97; for wooden- or concrete pole
- FLa 15/97; wide span system on concrete pole or steel cross arms
- FLa 15/97 - 64W; (switch angle 110°)

DRIESCHER - Outdoor Switch-Disconnecter FLa 15/97

Switching in a vacuum

• The trend is to use a vacuum

During the Sixties basic research began on switching in a vacuum. At this time low-oil switches had become firmly established in medium voltage networks, based on their reliable operation over decades, and were accepted by users as reliable devices. In laboratory tests it proved that the vacuum switches were superior by far to the conventionally applied switching principles.

The first experience with this vacuum technology was gathered using our line sectionalizers in overhead lines for railway operations, which have been successfully used since 1971.

In principle, the proven arcing chamber method has been maintained in the new switchgears which were developed in 1997.

In distribution networks a reliable power supply is the key criterion, wherein it is not the high number of operating cycles which is so important, but rather the high degree of reliability.

Even after many years of life the switchgear must make and break reliably.

All these requirements necessitate a switching unit with electrical properties that preferably do not change throughout its service life.

The vacuum interrupter is hermetically sealed and the purest materials ensure that the vacuum required for reliable switching remains intact throughout the entire service life.

Also the contact resistances remain at very low values as there is no oxidation process in a vacuum.

• **Advantages of the switch-disconnector FLa 15/97** over outdoor switch-disconnectors with conventional extinguishing media:

- faster dielectric recovery after the breaking process
- high insulation resistance
- short total travel
- compact operating mechanism
- low contact wear and consequently
- high operating frequency
- very long service life

Description of operation:

During the **disconnection** the main contacts open first, while the current is commutated to the shunt-connected current path, the pivot arm and the actuating fork.

Once a specified disconnecting position is reached the actuating fork operates the toggle mechanism inside the arcing chamber and causes the vacuum interrupter to disconnect.

The breaking arc in the vacuum arcing chamber is safely extinguished at the first current zero with **no external** arcing phenomena.

The continued movement of the hinged insulator then provides the visible isolating distance.

During the **making process** the pivot arm strikes the actuating fork (vacuum interrupter is still disconnected). After the continued movement of the hinged insulator or immediately before making contact with the main contact a visible pre-arcing occurs between the main contacts, which extinguishes when the main contact system has full current carrying capacity.

Immediately afterwards the shunted vacuum interrupter closes.

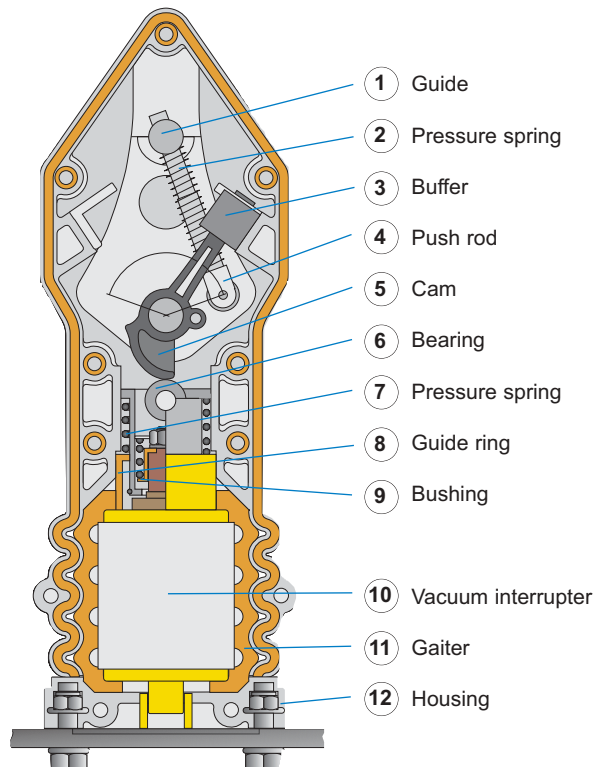

DRIESCHER - Outdoor Switch-Disconnecter FLa 15/97

Operation mode

• Breaking Operation

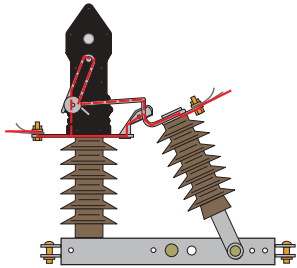

Switch in "ON" position
Main and secondary contact system
(vacuum interrupter) closed.

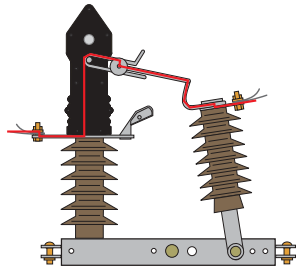

Switch during breaking phase.
The main contact system is already opened
when the secondary contact system
breaks (vacuum interrupter is shunted).

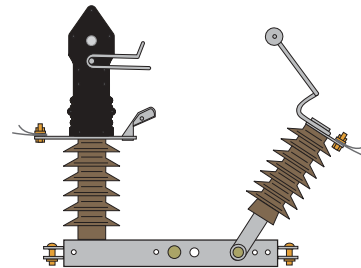

Switch in "OFF" position
Main and secondary contact system
(vacuum interrupter) open. The visible gap
is attained.

• Making Operation

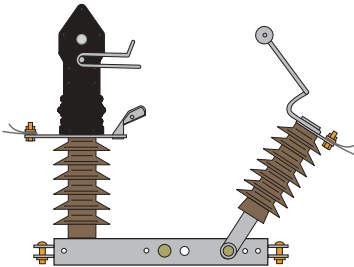

Switch in "OFF" position
Main and secondary contact
system (vacuum interrupter) open

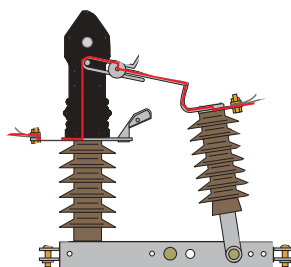

Switch during the making phase. The
main contact system is still open during
the closing via the secondary contact
system (vacuum interrupter is parallel
connected)

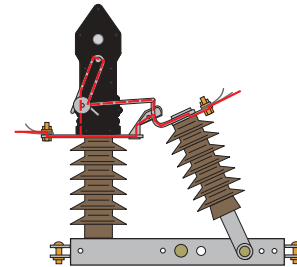

Switch in "ON" position
Main and secondary contact system
(vacuum interrupter) closed

Technical data

Type	FLa 15/97				
Rated voltage	U_r	12 kV	24 kV	36 kV	38.5 kV
Rated current	I_r	400 / 630 A	400 / 630 A	400 / 630 A	400 / 630 A
Rated mainly active load breaking current	I_1	630 A	630 A	630 A	630 A
Rated distribution line closed-loop breaking current	I_{2a}	630 A	630 A	630 A	630 A
Rated cable-charging breaking current	I_{4a}	25 A	25 A	-	-
Rated earth fault breaking current	I_{6a}	200 A	200 A	200 A	200 A
Rated cable breaking current under earth fault conditions	I_{6b}	32 A	32 A	32 A	32 A
Rated peak withstand current	I_p	40 kA	40 kA	40 kA	40 kA
Rated short time current (1 sec.)	I_k	16 kA ¹⁾	16 kA ¹⁾	16 kA ¹⁾	16 kA ¹⁾
Rated short-circuit making current	I_{ma}	25 kA	25 kA	10 kA	10 kA
Rated power frequency withstand voltage	U_d				
Leiter - earth / conductor - conductor break gap		28 kV / 32 kV	50 kV / 60 kV	70 kV / 80 kV	80 kV / 90 kV
Rated lightning impulse withstand voltage	U_p				
Leiter - earth / conductor - conductor break gap		75 kV / 85 kV	125 kV / 145 kV	170 kV / 195 kV	180 kV / 210 kV

1) This data applies also for earthing switch

DRIESCHER - Outdoor Switch-Disconnecter FLa 15/97

FLa 15/97 - for mounting horizontal on wooden or concrete pole

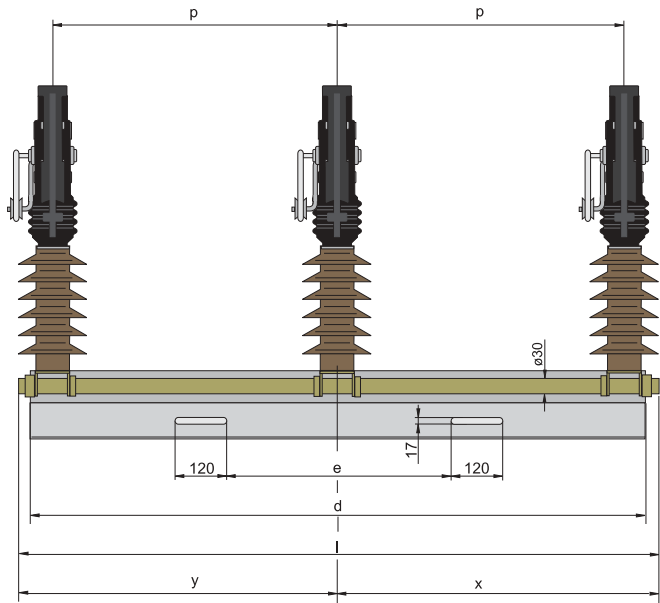
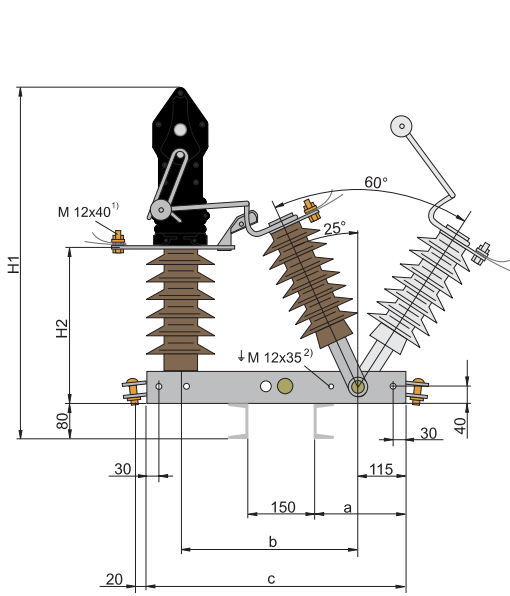

- 1) Hex head bolt (caulked) with nut, washer and spring washer
- 2) Hex head bolt with screw, washer and spring washer

without earthing switch

Rated voltage	Rated current	Part-no.	p	a	b	c	d	e	l	≈ H ₁	≈ H ₂	x/y	Weight approx.	Drawing-no.
12 kV	400 A	766 52011	700	215	405	600	1465	520	1530	774	363	765	110 kg	LT3-091445
24 kV	400 A	766 52011	700	215	405	600	1465	520	1530	774	363	765	110 kg	LT3-091445
24 kV	400 A	766 52013	1000	215	405	600	2065	520	2130	774	363	1065	125 kg	LT3-091445
24 kV	400 A	766 52014	1200	215	405	600	2465	520	2530	774	363	1265	135 kg	LT3-091445
36 kV	400 A	766 82013	1000	265	455	650	2065	460	2130	774	443	1065	140 kg	LT3-091979
36 kV	400 A	766 82014	1200	265	455	650	2465	460	2530	774	443	1265	150 kg	LT3-091979
38.5 kV	400 A													planning in stage

with earthing switch at side with chamber

Rated voltage	Rated current	Part-no. with earthing switch	p	Weight approx.	Drawing-no.
12 kV	400 A	766 22111	700	115 kg	LT3-091445
24 kV	400 A	766 52111	700	125 kg	LT3-091445
24 kV	400 A	766 52113	1000	145 kg	LT3-091445
24 kV	400 A	766 52114	1200	160 kg	LT3-091445
36 kV	400 A	766 82113	1000	170 kg	LT3-091979
36 kV	400 A	766 82114	1200	170 kg	LT3-091979
38.5 kV	400 A				planning in stage

Equipment with auxiliary switches or motordrive only if ordered additionally.

Switches with rated current 630 A, please send inquiry (Connection with Cu-tensions straps with 4 layers).

DRIESCHER - Outdoor Switch-Disconnecter FLa 15/97

Mounting supports

for switch-disconnectors see on page 6

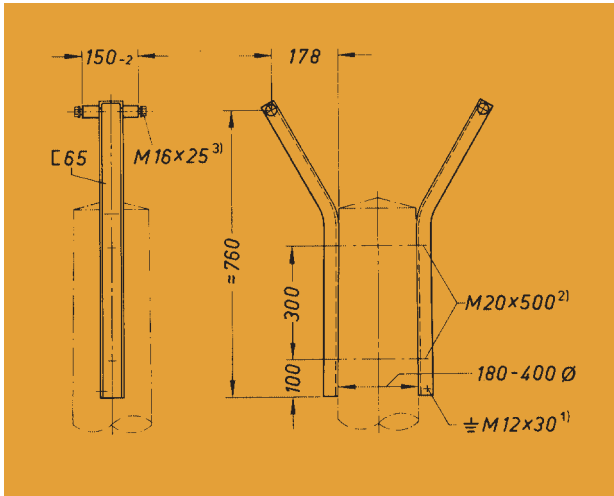

on single pole

Drawing no. FT 4-44328 • Part no. 760 10124
Weight (with accessories) approx. 14.4 kg

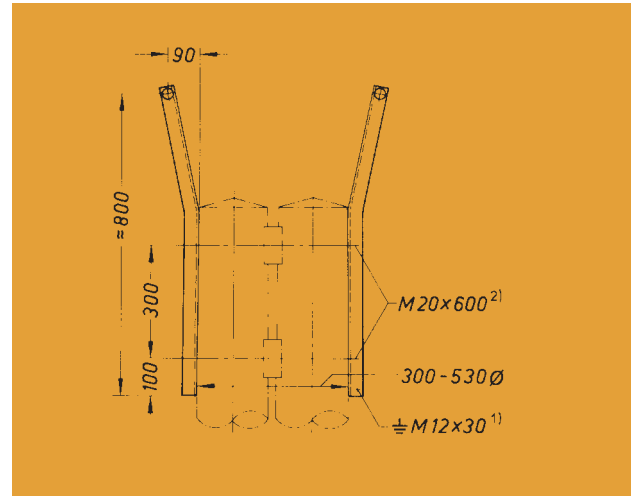

on double pole

Drawing no. FT 4-44328 • Part no. 760 10130
Weight (with accessories) approx. 15.4 kg

- 1) Hexagonal screw with nut and spring washer
2) Gewindebolt with nut and washers
3) Hexagonal screw and washer

Cu-tension straps (3 x 30 x 1, tin-plated) • Standard lengths

Part-no.	531 71004	531 71006	531 71009	531 71011
Lengths	1100 mm	1340 mm	1540 mm	1740 mm (special length)

Switch mounting	Anchoring	For rated voltage kV	Straps lengths		quantity of straps each side and each pole • 400 A
			Fixed insulator side	Hinged insulator side	
On wooden or concrete pole	Single staying	12	1100	1340	1
On wooden or concrete pole	Single staying	24	1100	1340	1
On wooden or concrete pole	Single staying	36	1340	1540	1
On wooden or concrete pole	Double staying	12	1340	1340	1
On wooden or concrete pole	Double staying	24	1340	1340	1
On wooden or concrete pole	Double staying	36	1540	1640	1
On concrete cross-arms (wide span system)	Single staying	24	1340	1540	1
On concrete cross-arms (wide span system)	Single staying	36	1340	1540	1
On concrete cross-arms (wide span system)	Double staying	24	1540	1540	1
On concrete cross-arms (wide span system)	Double staying	36	1540	1540	1

Note: The tension straps with 3 layers 30 x 1 mm each are riveted together in the centre (page 9).

DRIESCHER - Outdoor Switch-Disconnecter FLa 15/97

FLa 15/97 wide span system for mounting on concrete cross-arms

For wide span system - comprising 3 single poles interconnected using coupling shafts

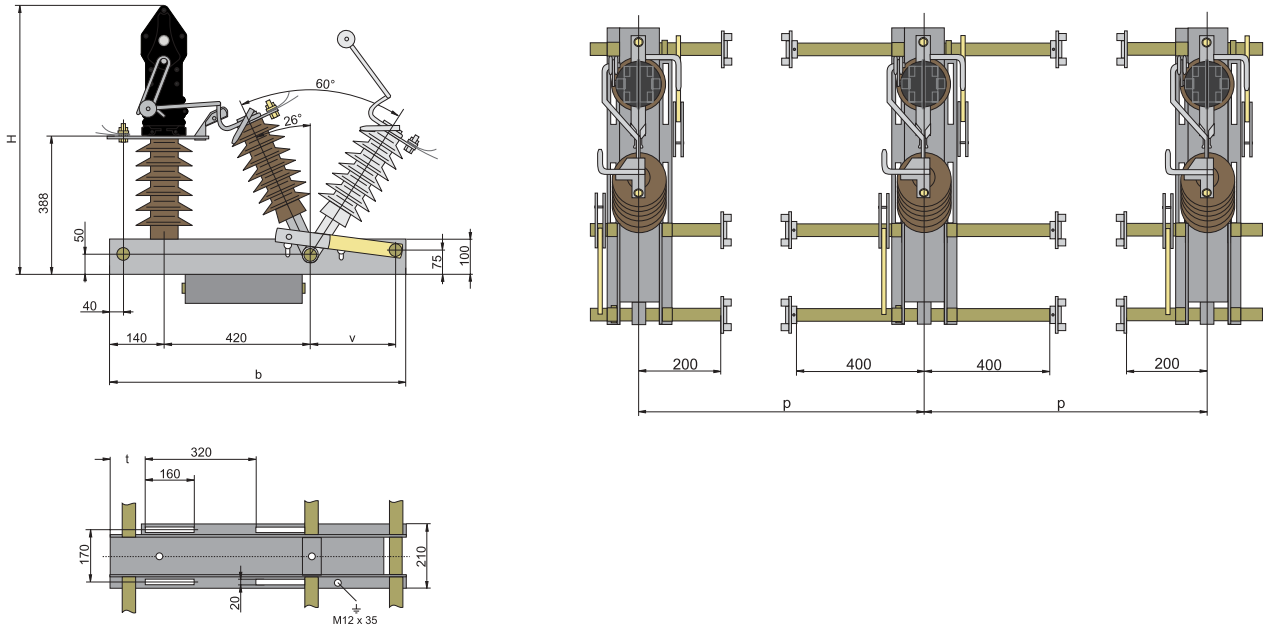

• without earthing switch

Rated voltage kV	Rated current A	Part-no.	p	≈ H	b	t	Weight approx. kg ²⁾	Drawing-no.
24	400	766 56051	of 1000 mm to 2400 mm stepped	719	670	100	97.0	LT3-091977
36	400	766 86051	by 200 mm respectively ³⁾	774	990	135	118.0	in planning

• with earthing switch

Rated voltage kV	Rated current A	Part-no.	Earthing switch	b	Weight approx. kg ²⁾	Drawing-no.
24	400	766 56151	Fixed insulator side	670	113	LT3-091977
24	400	766 56251	Hinged insulator side	840	119	LT3-091978
24	400	766 56351	Fixed and hinged insulator side	840	135	LT3-091978
36	400	766 86151	Fixed insulator side	990	134	planning
36	400	766 86251	Hinged insulator side	990	134	in
36	400	766 86351	Fixed and hinged insulator side	990	150	stage

2) The weights include the CU tension straps, but not the coupling shafts (for dimensions of Cu tension straps please refer to table on page 7)

3) For dimensions and weights and part numbers of the coupling shafts please refer to following table

Coupling shafts for switch-disconnectors (wide span system)

Pole distance p	Shaft diameter	Part-no.	2 coupling shafts for switch without earthing switch Weight approx. kg	4 coupling shafts for switch with earthing switch Weight approx. kg	6 coupling shafts for switch with 2 earthing switches Weight approx. kg	Drawing-No. AZ 4-38254
1000	30	641 14460	4.5	9.0	13.5	
1200	30	641 14360	6.7	13.4	20.1	
1400	30	641 14370	8.9	17.8	26.7	
1600	30	641 14390	11.1	22.2	33.3	
1800	30	641 14400	13.3	26.6	39.9	
2000	40	641 14420	28.0	56.0	84.0	
2200	40	641 14430	32.0	64.0	96.0	
2400	40	641 14440	36.0	72.0	108.0	

DRIESCHER - Outdoor Switch-Disconnecter FLa 15/97

FLa 15/97 wide span system - arrangement according to system "Tonnenbild"

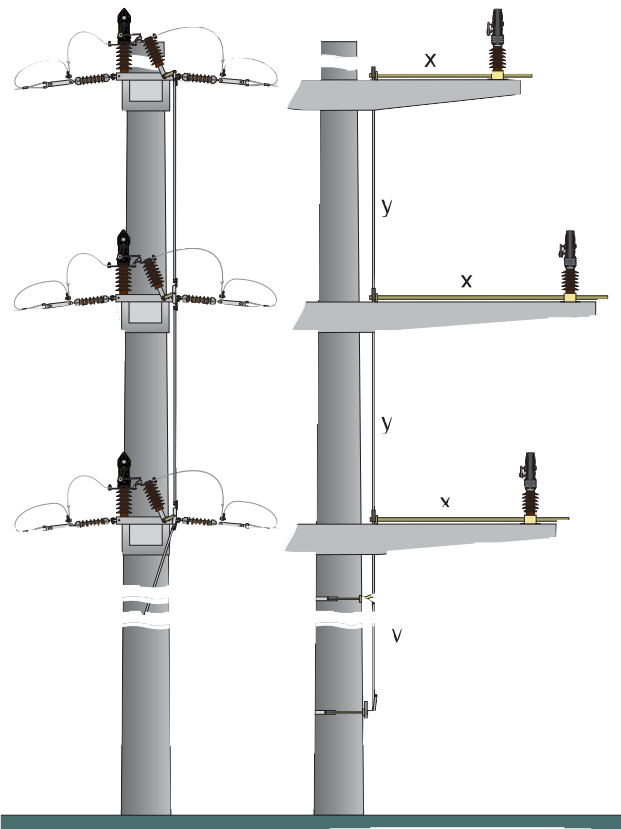

Switch-disconnecter FLa 15/97 in Three-plane arrangement

- comprising 3 single poles which are mounted on cross-bars arranged one above the other
- Joint actuation of the 3 poles is implemented using a vertical operating linkage

The distances marked with x and y can be determined accordingly

Switch dimensions see page 8

Arrangements of operating mechanisms for wide span system

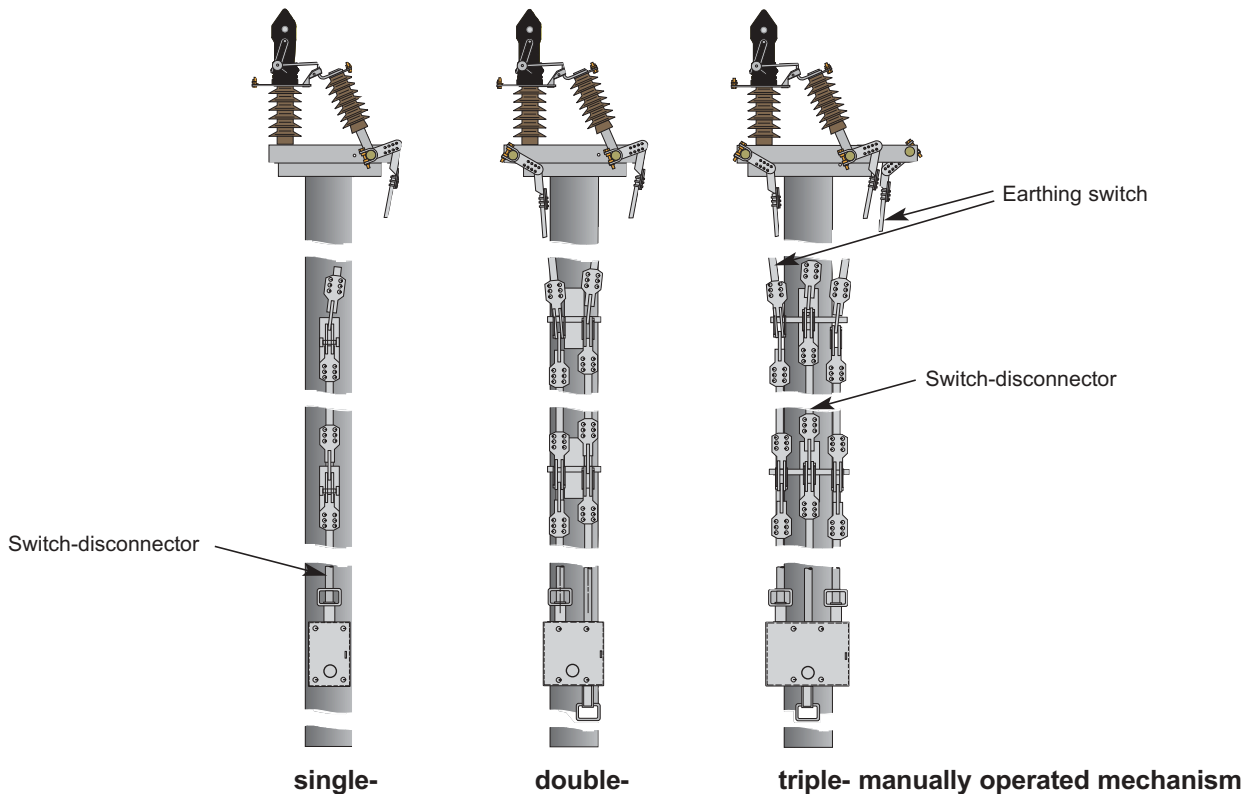

DRIESCHER - Outdoor Switch-Disconnecter FLa 15/97

Underframe

for wide span system (drawing no. LH 3-43667) • Underframe fully assembled for three-pole switch-disconnector • rated voltage 24 kV
Part no. 760 20120 (drawing no. LH 4-44069), weight approx. 32 kg, for oversized concrete cross-arms

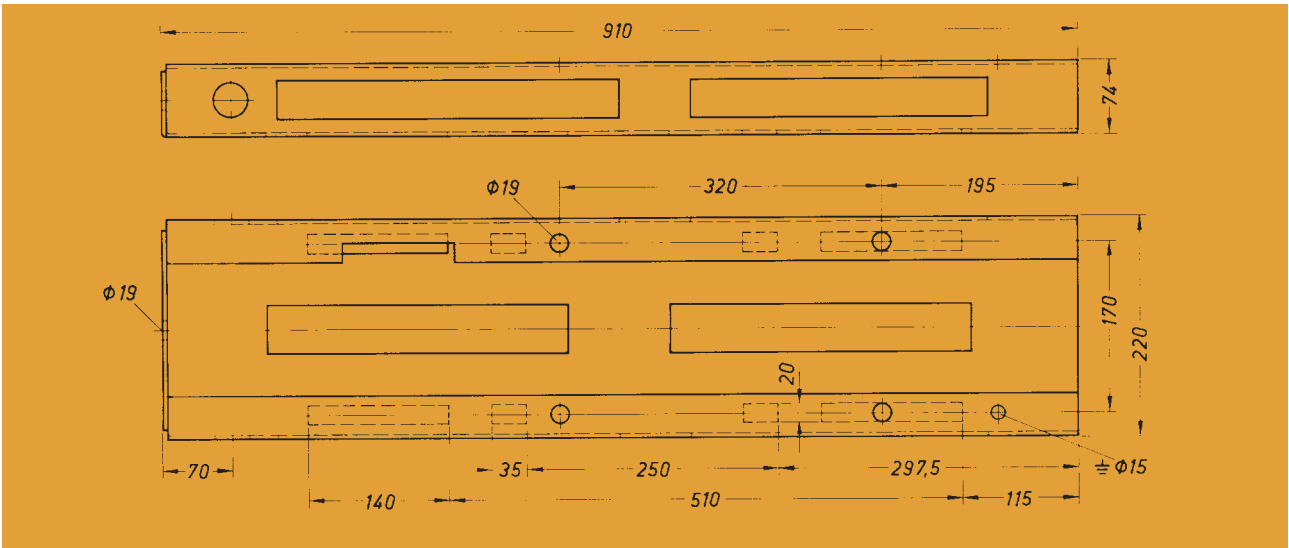

Support bearing

For switch-disconnectors without earthing switch for mounting on concrete cross arms (page 10) with appropriately cast threaded bushes

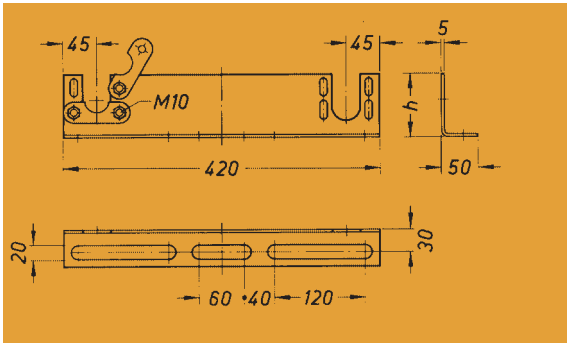

Underframe	Part-no.	h	Weight approx. kg	Drawing-no.
without	760 20105	85	1.9	LH 4-44099
with	760 20106	159	3.1	LH 4-44099

Support bearing

For switch-disconnectors with earthing switch for mounting on concrete cross-arms with appropriately cast threaded bushes

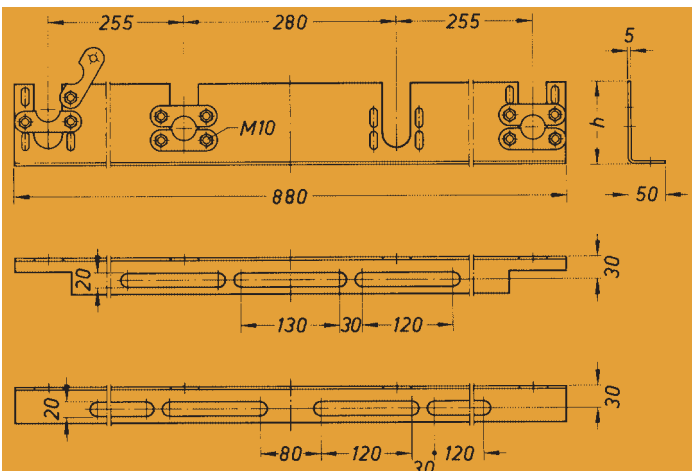

Rated voltage	Underframe	Part-no.	h	Weight approx. kg	Drawing-no.
24 kV	without	760 20105	85	1.9	LH 3-42752
24 kV	with	760 20106	159	3.1	LH 3-42753

Support bearing for switch-disconnectors with earthing switches, rated voltage 36 kV, on request

DRIESCHER - Outdoor Switch-Disconnecter FLa 15/97

Design of tension units

Single staying

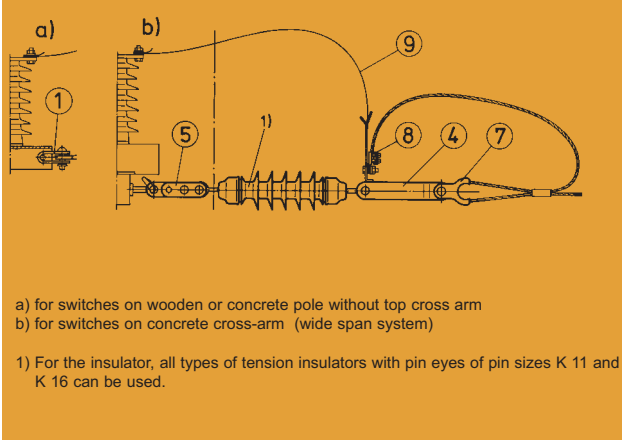

Double staying

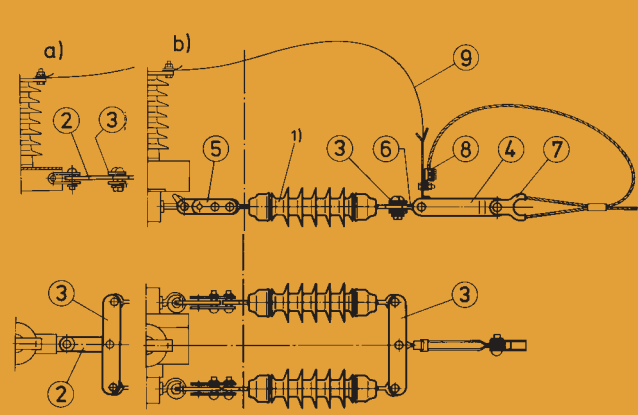

Permissible tension angle

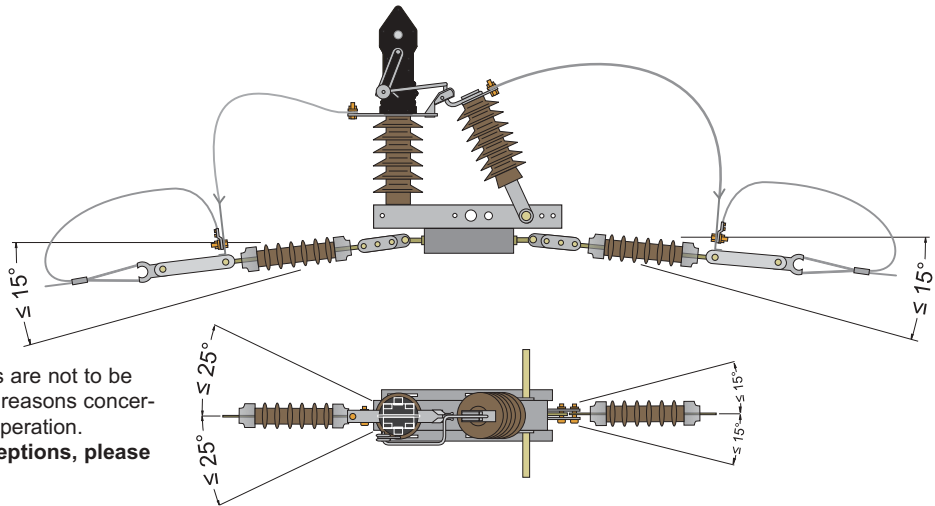

The specified angles are not to be exceeded based on reasons concerning the functional operation.
In the event of exceptions, please consult us first.

Concrete cross arm

For mounting an outdoor switch-disconnector FLa 15/60 with tension units

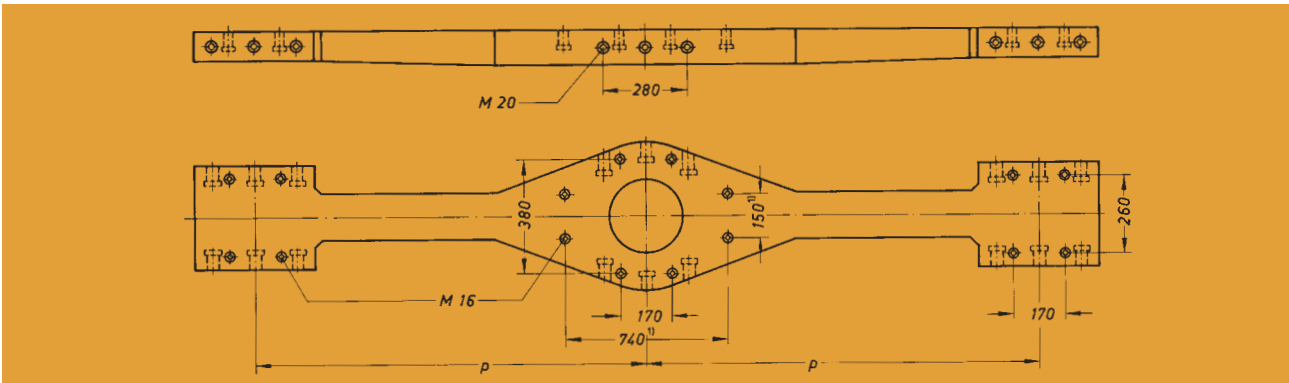

1) cast threaded bushes for shaft support bearings

Remark: For peak tensions (>30 kN) underframes are usually required for breaker pole mounting (see page 8).

DRIESCHER - Outdoor Switch-Disconnecter FLa 15/97

FLa 15/97-64W (horizontal mounting)

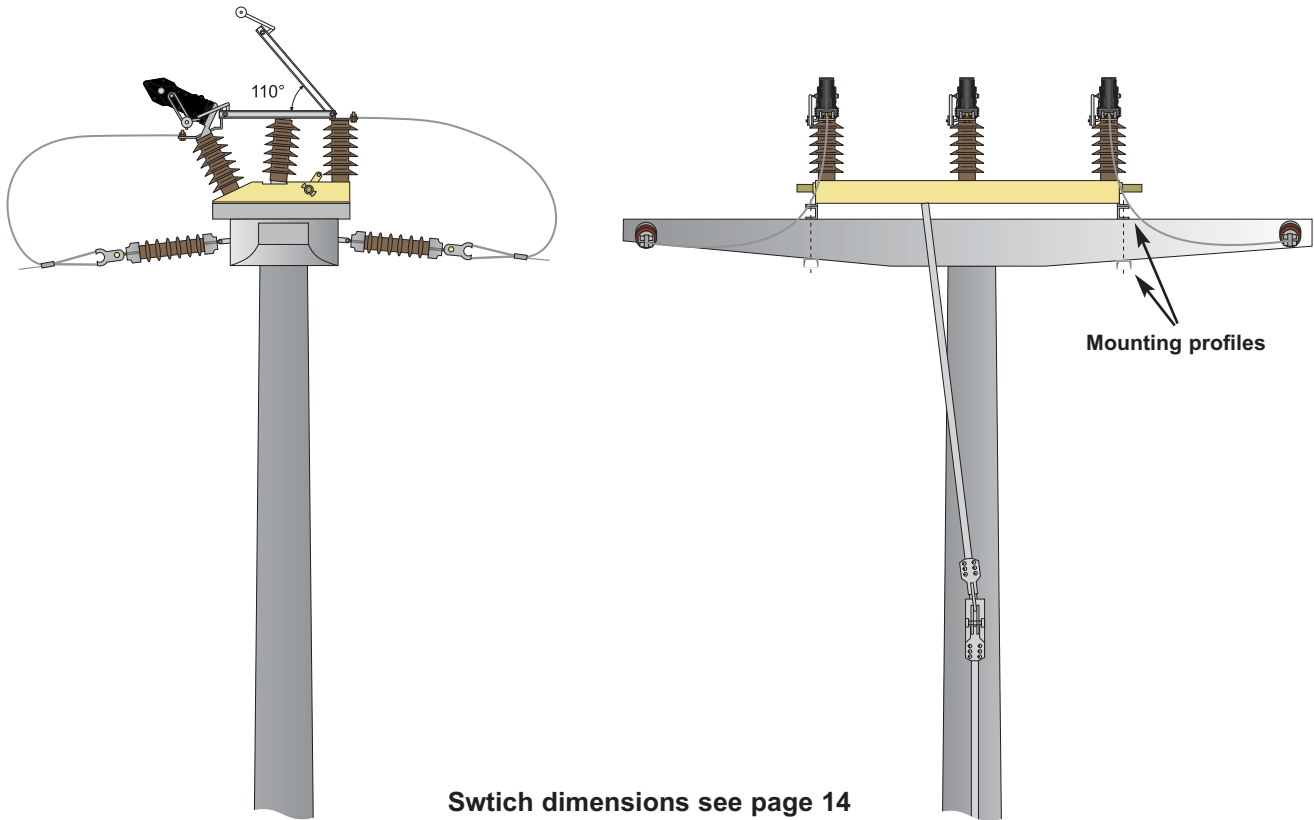

- Phase spacing $p = 500$ and $P = 700$ mm are possible
- For retrofitting existing concrete column lines
- With appropriate mounting profiles also possible for mounting on cross-bars
- Available with bird protection upon request







Attention:

With type FLa 15/97- 64 W (horizontal) always make sure that the insulator crank is applied right up to the dead center position in order to avoid any unintentional closing of the switch in the event of a defective operating mechanism. The switching angle is therefore 110° in this case. (Function of an over dead center switching)

Should you desire more detailed information, we would be pleased to forward this to you!

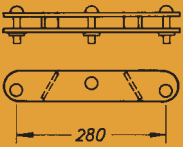
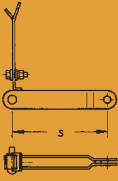
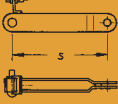
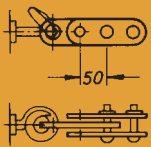
DRIESCHER - Outdoor Switch-Disconnecter FLA 15/97

Accessories for tension units

	Designation	Part-no.	Drawing-No.	Weight approx. kg
① 	Small suspension hinge for switch On wooden or concrete pole without top cross arm (see page 5) (suspended in switch frame)	2-760 10121	FT 4-17086	0,8
② 	Strap for spacer	2-515 11064	FT 4-17090/1	1,0
③ 	Spacer			
④ 	Forked strap s=100 mm for switch on wooden pole	2-775 43010	FT 4-38202/1	1,2
④ 	Forked strap s=250 mm for horn-break switch in wide span system version	2-775 42010	FT 4-38202/2	1,9
⑤ 	Adjustable strap for switch on concrete pole with T-head cross arm in wide span system version (adjustable by 50 mm)	2-760 20111	FT 4-15728	2,1
⑥ 	Tensioning stiffener up to 70 mm ²			
⑦ 	Clamping cable lug 35 to 70 mm ² (required in addition)			
⑧ 	Cu tension straps 3 x 30 x 1 mm L= 1100 mm L= 1340 mm L= 1540 mm L= 1740 mm	2-531 71004 2-531 71006 2-531 71009 2-531 71011	WN 4-37028	0,9 1,1 1,3 1,4

DRIESCHER - Outdoor Switch-Disconnecter FLa 15/97

FLa 15/97-6400

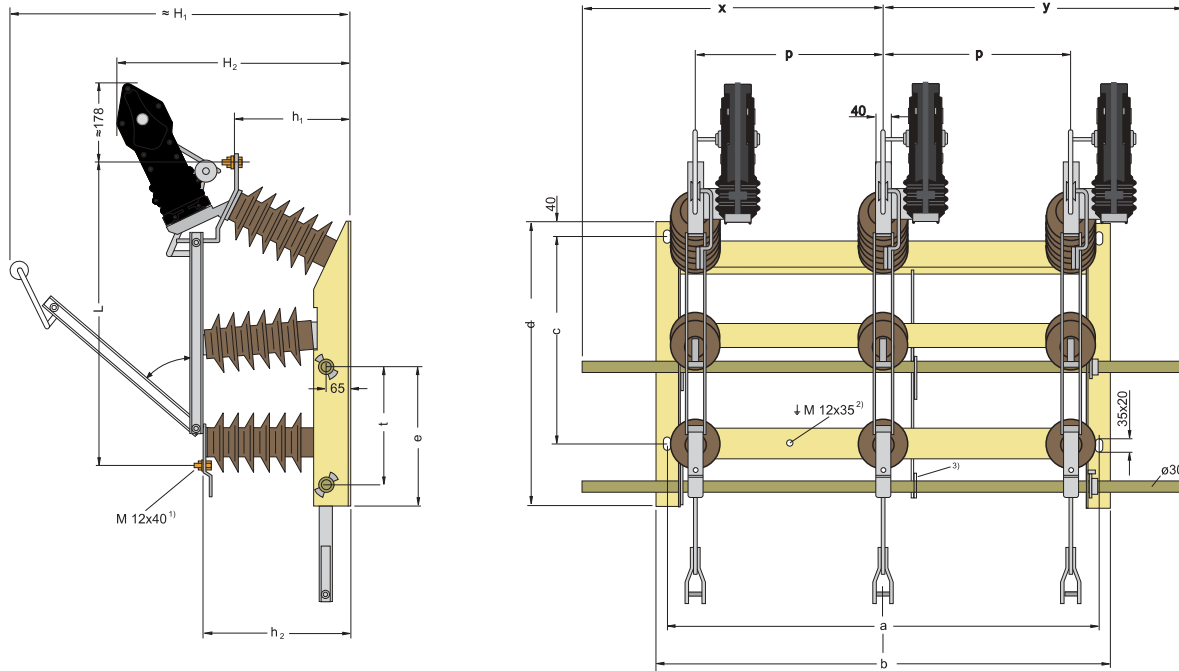

- 1) Hex head bolt (caulked) with nut, washer and spring washer
 2) Hex head bolt with screw, washer and spring washer
 3) Support bearing for earthing switch shaft (only for 36 kV)

• without earthing switch

Rated voltage	Rated current	Part-no.	p	a	b	c	d	e	L	$\approx H_1$	$\approx H_2$	h_1	h_2	x/y	Weight approx.
12 kV	630 A	767 34002	400	950	1010	500	710	360	741	845	345	261	322	700	99 kg
24 kV	630 A	767 64003	500	1150	1210	550	760	375	793	923	575	311	392	800	109 kg
36 kV	630 A	767 94004	700	1550	1610	750	960	574	1044	1162	731	390	472	950	126 kg

• with earthing mounted below, mechanical interlocking

Rated voltage	Rated current	Part-no. with earthing switch	p	t	Weight approx.	Drawing-no.
12 kV	630 A	767 34502	400	315	115 kg	LT3-091444
24 kV	630 A	767 64503	500	315	125 kg	LT3-090964
36 kV	630 A	767 94504	700	390	145 kg	LT3-091894

Attention!

- Switch angle of the switch-disconnector 90°
- Also possible for horizontal mounting (switch angle 110°, see page 12)
- Equipment with auxiliary switches or motordrive only if ordered additionally.

DRIESCHER - Outdoor Switch-Disconnecter FLa 15/97

Single pole outdoor switch-disconnector FLa 15/97 - 6400

for earth fault neutralizer

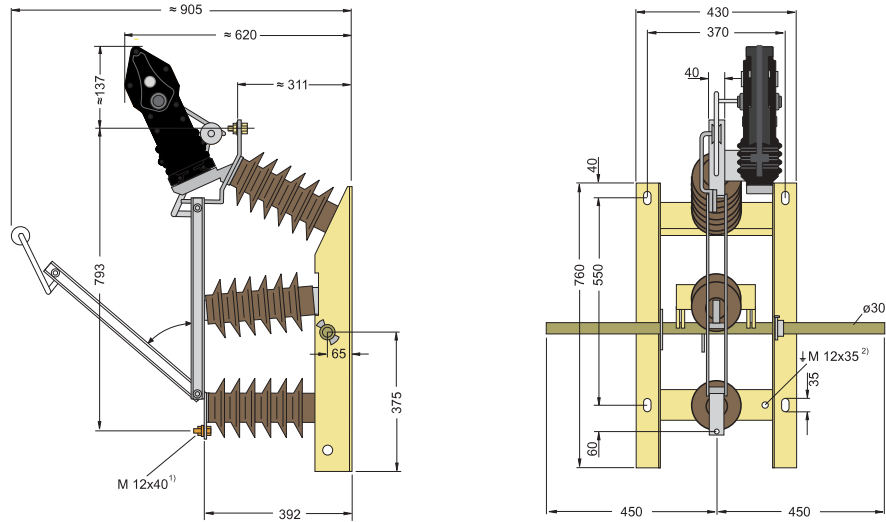

- 1) Hex head bolt (caulked) with nut, washer and spring washer
 2) Hex head bolt with screw, washer and spring washer

Rated voltage kV	Rated current A	Part-no.	Weight approx.	Drawing-no.
24	630	767 62 001	43 kg	LT3-091997

Equipment with auxiliary switches or motordrive only if ordered additionally.

DRIESCHER - Outdoor Switch-Disconnecter FLa 15/97

FLa 15/97-6410 SA with fuse holders mounted below

with fuse holders mounted below for pin operated HV-HBC fuses of up to 200 A rated current

The SA special version of the outdoor fused switch-disconnector FLa 15/6410 which has been well-proven over decades under very versatile operating conditions, has a disconnecting energy storage mechanism which carries out all-pole interruption of the switch if a HV-HBC fuse operates (with a tripping impact force of 120 N). It is therefore possible to also benefit from the advantages of the HV-HBC fuses **with thermal protection** in outdoor applications as well. The energy storage mechanism (patent application filed) is designed in such a way that no additional effort has to be applied

when manually operated using the hand crank. Following a disconnection through operation of the fuse (SA) the stored energy mechanism is tensioned in the OFF position after the return of the operating mechanism. After changing the fuse and switching on, the switch is ready to interrupt again. Stored energy mechanism and interrupting mechanism are securely housed in a hot galvanised steel plate housing which is also vented. Transparent covers protect the release mechanism at the upper contact clips of the HV-HBC fuses respectively.

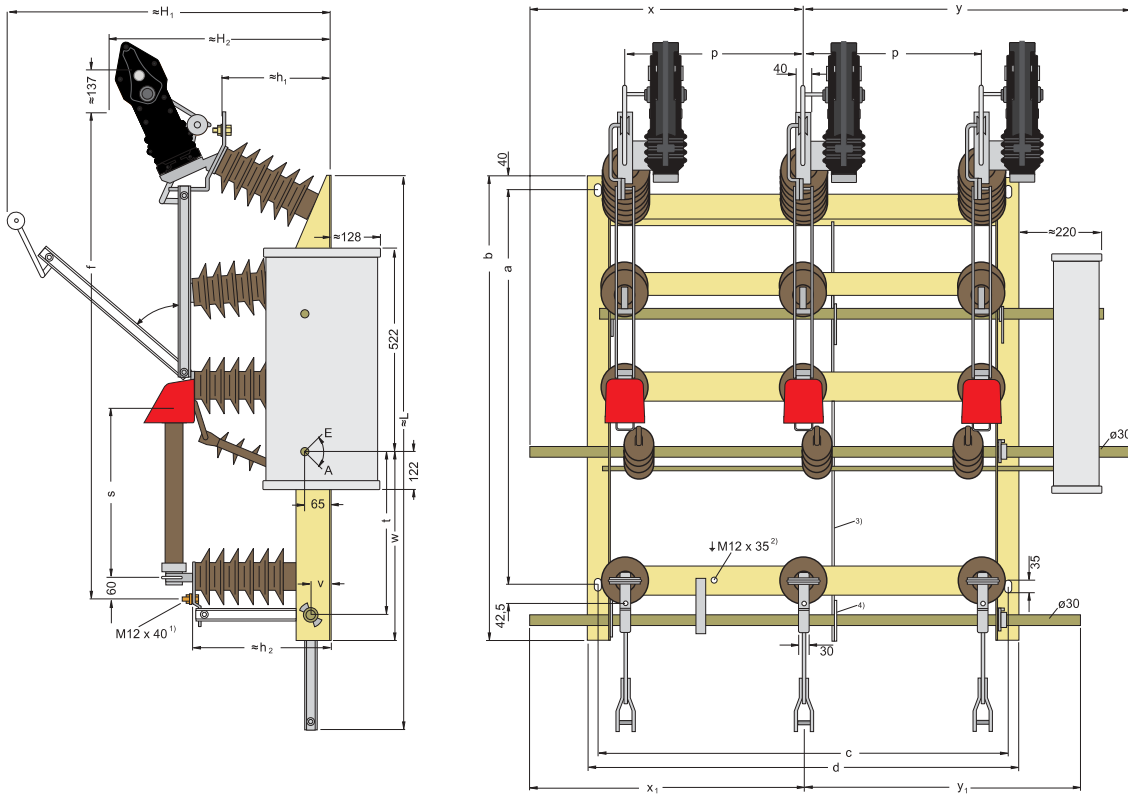

without earthing switch

Rated voltage kV	Rated current A	
12	630	planning in stage
24	630	
36	630	

with earthing switch

Rated voltage kV	Rated current A	p	s	t	v	x ₁	y ₁	Weight kg	Drawing-no.
12	630	400	325	307	75	700	700	127	planning
24	630	500	475	472	65	planning in stage	800	800	168
36	630	700	570	642	65	950	950	229	stage

Equipment with auxiliary switches only if ordered additionally.

DRIESCHER - Outdoor Switch-Disconnecter FLa 15/97

Arrangements of operatings (examples)

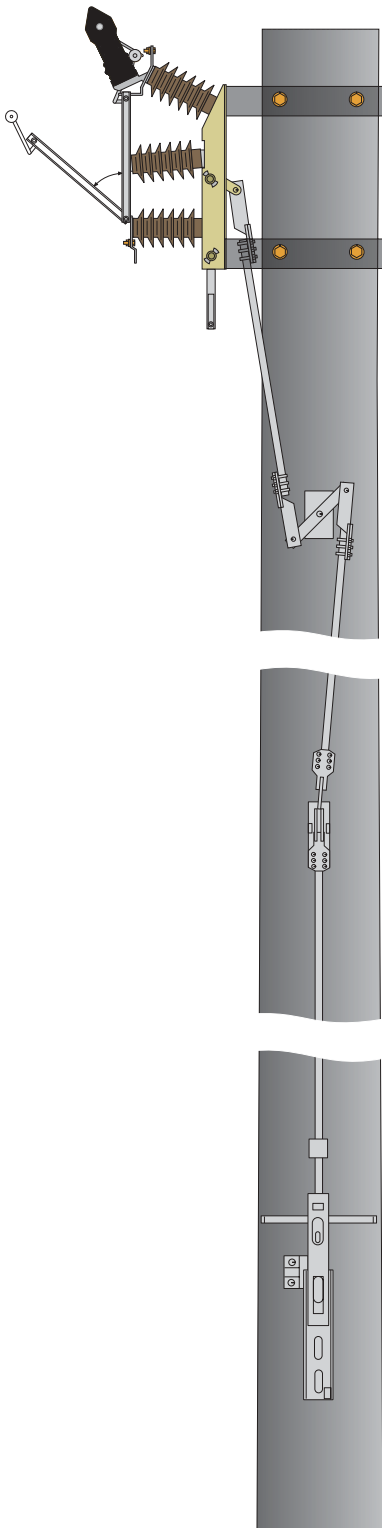

FLa 15/97-6400

- without earthing switch
- single manually operated mechanism

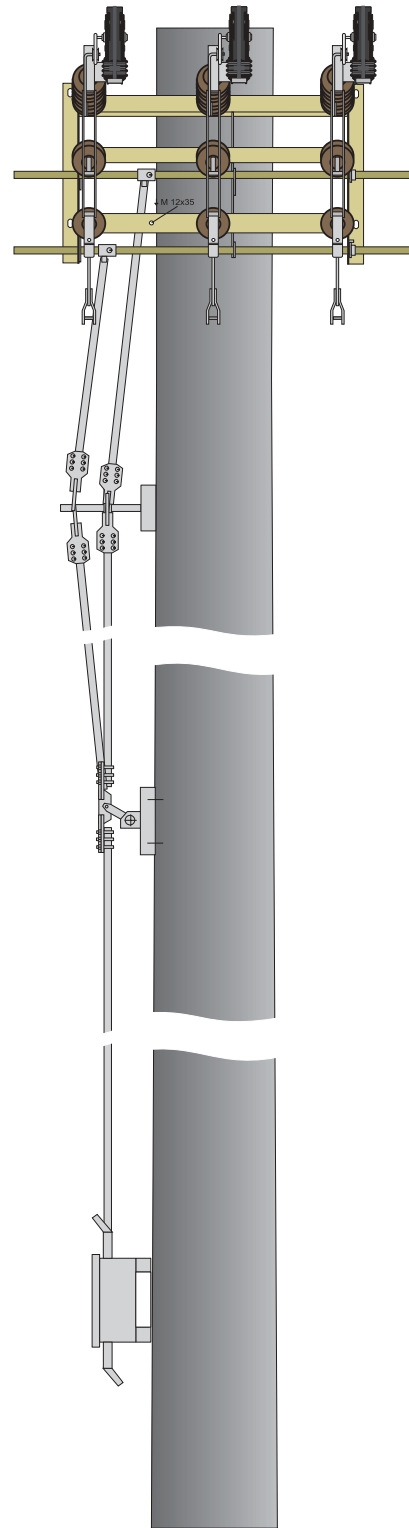

FLa 15/97-6400

- with earthing switch
- double manually operated mechanism

DRIESCHER - Outdoor Switch-Disconnecter FLa 15/97

Operators (see brochure 776)

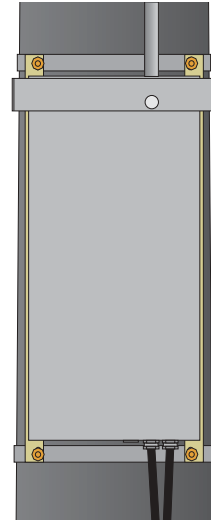
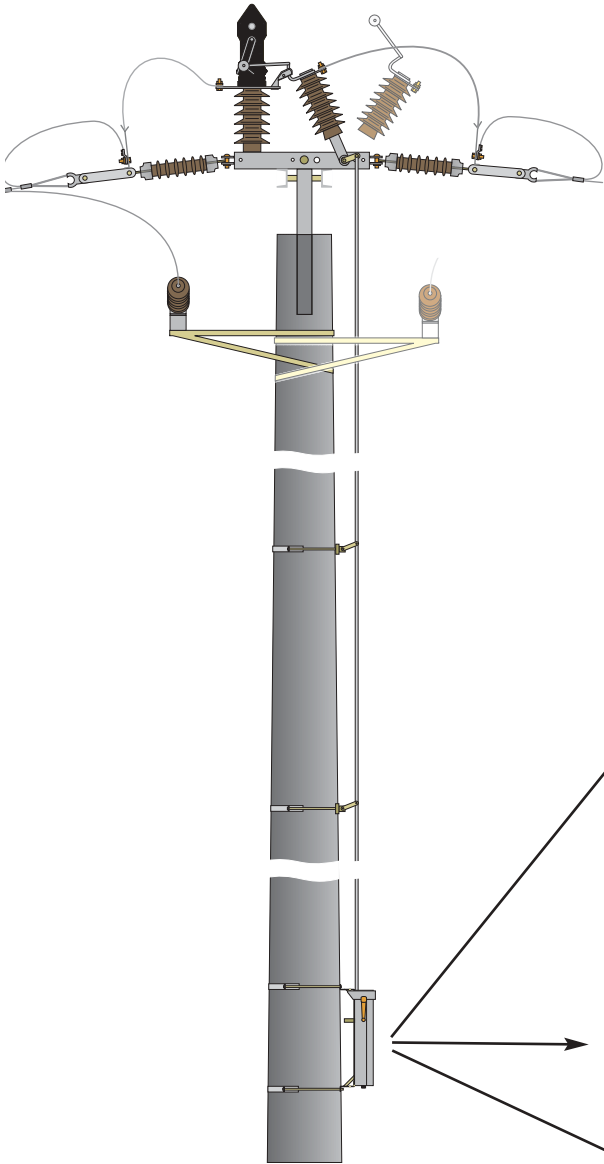

Example 1:
Motordrive UM90 for
remote control (drawing)



Example 2:
control unit with mounted
motordrive UM20
for radio control

single
manually operated mechanism

Example 3:
double
manually operated mechanism

triple
manually operated mechanism

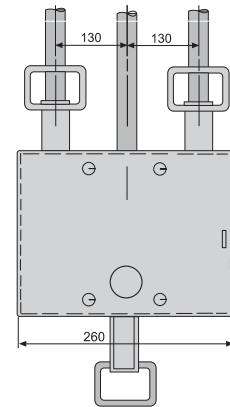
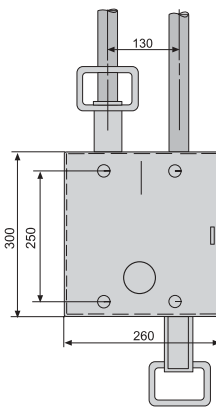
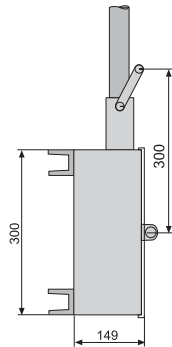
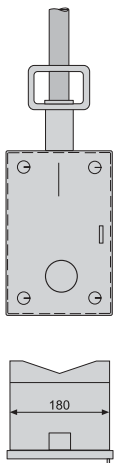

Examples of use

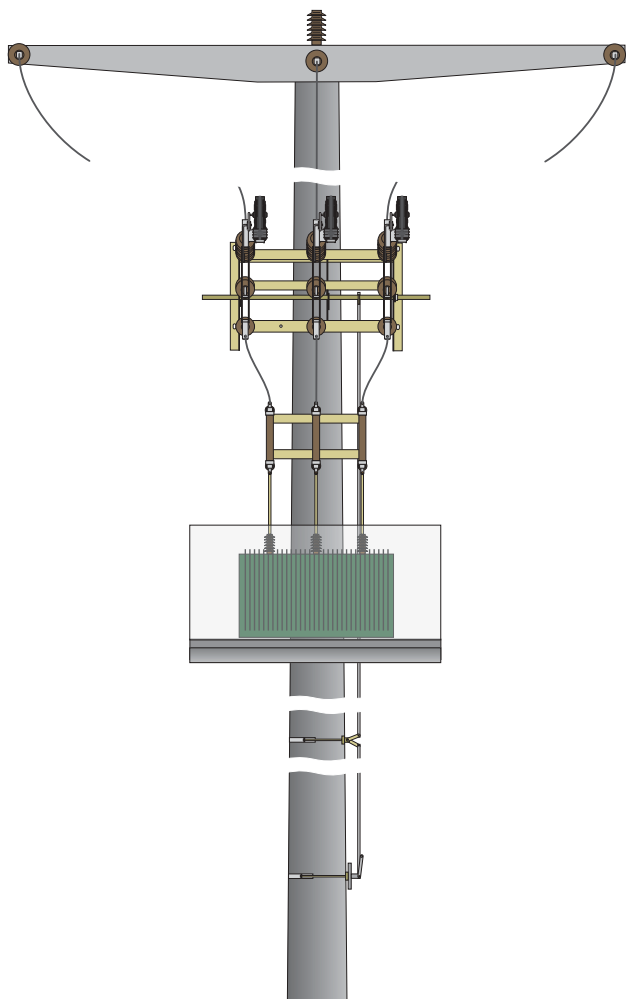

Example 1:
FLa 15/97 -6400 for transformer stations

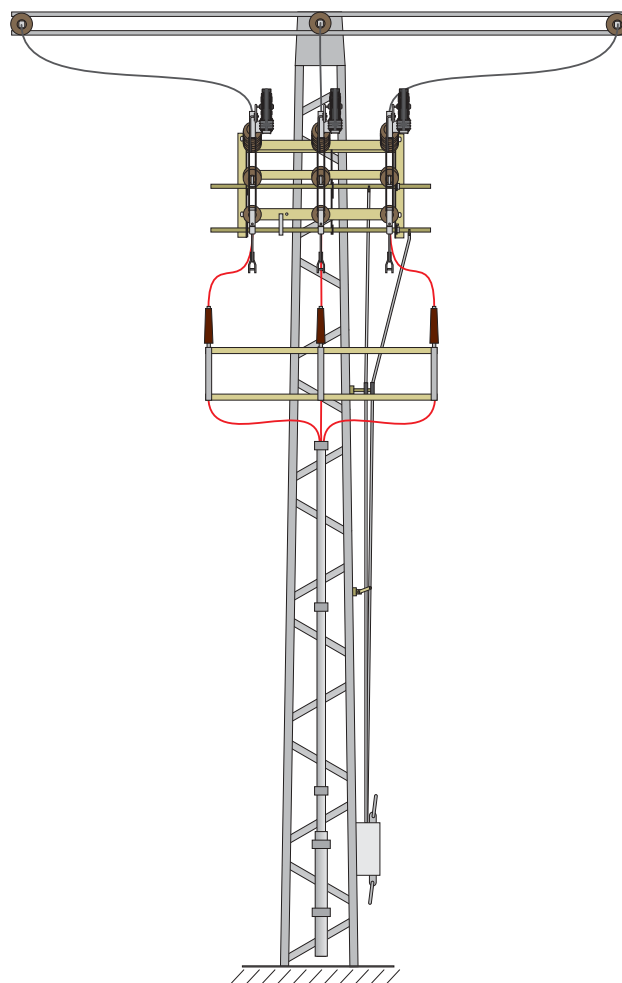

Example 2:
FLa 15/97 -6400 for outgoing cable
with earthing switch

Dimensions, weights, diagrams and descriptions in the list are non-binding. Subject to change without notice.

switching • electricity • safely

Printed on chlorine free bleached paper. For nature's sake.

**ELEKTROTECHNISCHE WERKE
FRITZ DRIESCHER & SÖHNE GMBH**

D-85366 MOOSBURG • TEL. +49 87 61 6 81-0 • FAX +49 87 61 68 11 37
<http://www.driescher.com> infoservice@driescher.de

